

Fitting Instructions

How to modify a europrofile cylinder to fit the SS50EM, SS50CEM, SB50EM, SB50CEM padlocks

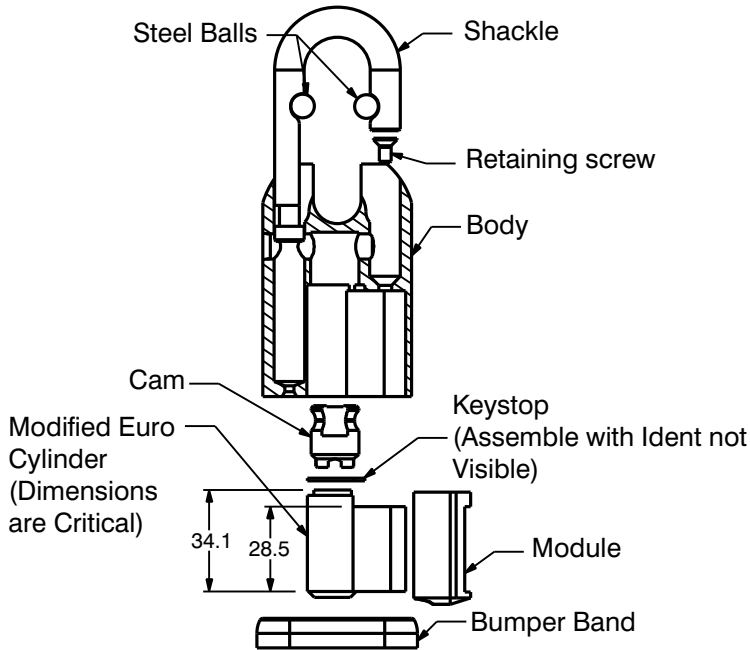

1. Remove module
2. Modify a euro cylinder to dimensions shown and insert into Module and then into padlock body.
3. Lock and unlock padlock to ensure correct operation. Insert retaining screw and tighten

1 A single or double cylinder can be modified. A 71mm equal sided double is recommended.
N.B. Remember you now have two cylinders - more keys may be required.

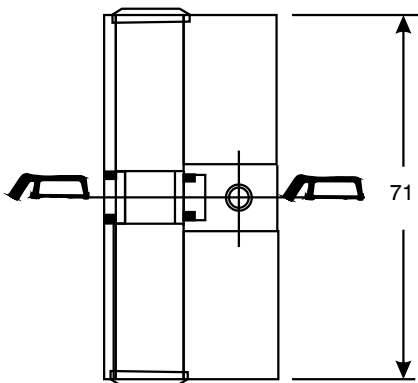

2 Modify it by cutting and filing

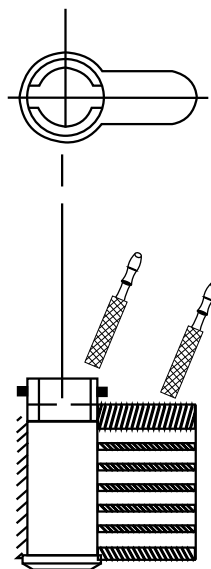

3 The modified cylinder should have these dimensions which are critical

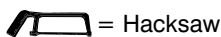
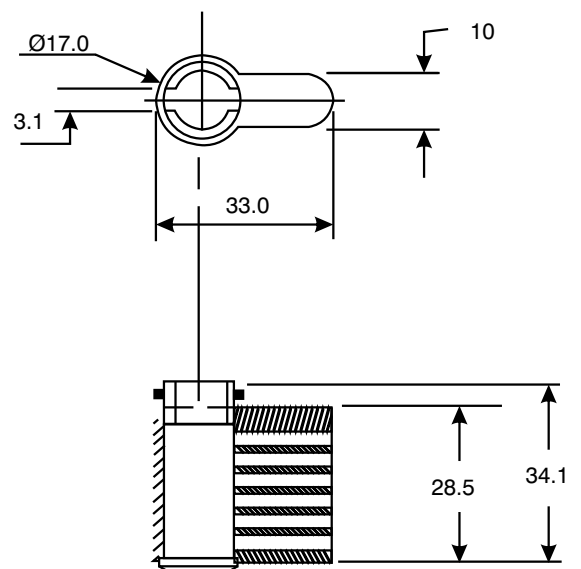

All Dimensions in Metric