

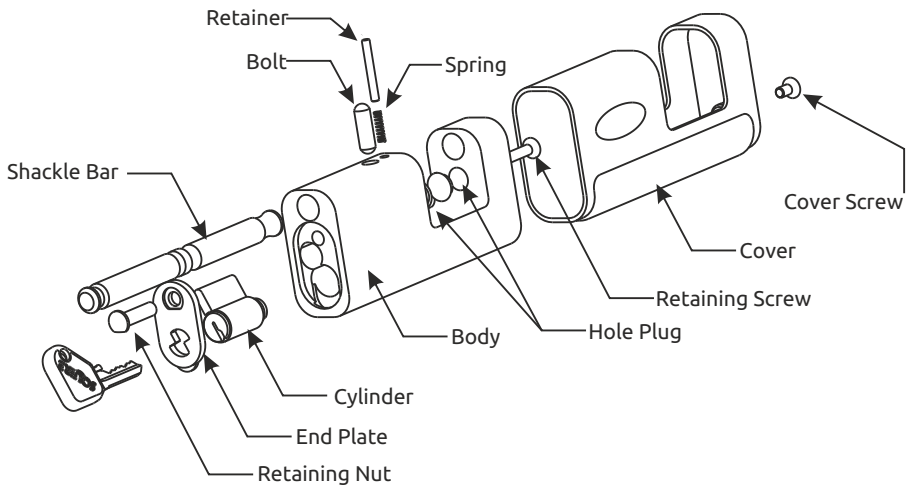

Fitting Instructions

How to change the cylinder in the **Stronghold® BULLIT™ WS50P5** lock

Assembly Drawing



Henry Squire & Sons Limited

Hilton Cross Business Park, Cannock Road, Featherstone, Wolverhampton, WV10 7QZ

Tel: 01902 308050

Fax: 01902 308051

E-Mail: info@henry-squire.co.uk

Website: www.squirelocks.co.uk



Fig. 1

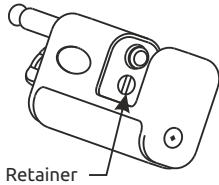

Retainer

Fig. 2

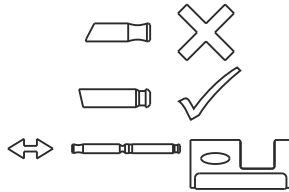
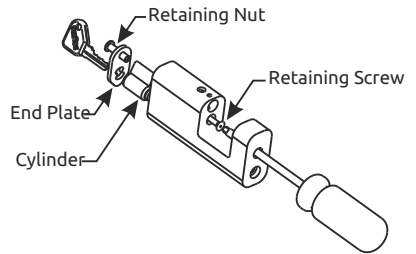

Fig. 3



Fitting Instructions

IMPORTANT NOTES: READ ALL INSTRUCTION BEFORE PROCEEDING.

NOTE: - DO NOT REMOVE OR REPLACE THE SHACKLE BAR WITH THE COVER REMOVED (Danger of flying parts) .

1. Remove the two hole plugs.
2. Insert the key and open the lock fully.
3. Use a pair of suitable bent long nose pliers to firmly grasp the retainer through the hole (see Fig1) and push down the retainer to depress the spring at the same time pulling the shackle bar free of the body.

IMPORTANT:- Note the alignment of the shackle in the body (see Fig2)
4. Remove the cover screw and the cover.
5. Remove the bolt, retainer and spring to expose the Retaining screw.
6. Remove the retaining screw (see Fig3). (Pozi-drive screwdriver required).
7. Remove the end plate/retaining nut to access the cylinder.
8. Remove the cylinder (Note the orientation of the cam on the cylinder).
9. Replace the cylinder as required.
10. Re-insert the end plate/retaining nut and operate the key until the cylinder locates on the cam.
11. Replace the retaining screw
12. Insert the spring, followed by the retainer.
13. Replace the bolt.
14. Replace the cover/cover screw.
15. With the lock in the open position depress the retainer and fully insert the shackle

IMPORTANT:-Ensure that the shackle is correctly aligned (see Fig2)
16. Check that the lock functions correctly.
17. Replace the hole plugs.

Henry Squire & Sons Limited

Hilton Cross Business Park, Cannock Road, Featherstone, Wolverhampton, WV10 7QZ

Tel: 01902 308050

Fax: 01902 308051

E-Mail: info@henry-squire.co.uk

Website: www.squirelocks.co.uk